



Special offer

Inventory number: 19561

5-axis machining center
DMG DMU 60 P hy-din
HEIDENHAIN MillPlus /3R-WorkMaster
+3R-WorkShopManager
2001



Price: 45,000.00 CHF

Machines in special offers are sold in AS-IS condition,

without any functional guarantee or mechanical/technical inspection from our side.

Technical data

Number of axis simultaneous	5
Number of tables	1
Number of spindles	1
Circularly table diameter	630 mm
Number of T-channels	9
Distance of the T-slots	63 mm
T-channel width	14H7 mm
Centering bore diameter	50H6 mm
Longitudinal travel (X-axis)	600 mm
Transversal travel (y-axis)	700 mm
Vertical travel (z axis)	600 mm
Dimension of the workpice:	
Height	1000 mm
Diameter	920 mm
Table load max.	500 kg
Table divisions (B)	360 °
A axis	
Swivel angle (a-axis)	+45/-30 °
Holding torque A-axis	3866 Nm
Clamping torque C-axis	6008 Nm
Torque max.	2650 Nm

Tool changer:

Number of tools	180
Tool diameter	80 mm
Diameter with free adjacent pockets	160 mm
Tool length	350 mm
Max. tool-weight	10 kg

Spindle nose SK 40 DIN 69871

Spindle speeds:

stepless	
up to	18000 rpm

Feeds:

stepless	
longitudinal from	20 mm/min
up to	15000 mm/min
transversal from	20 mm/min
up to	15000 mm/min
vertical from	20 mm/min
up to	15000 mm/min

Rapid traverse: 40 m/min

Measurement system:

Resolution	0.001 μ m
Air connect	5 - 8 bar
Voltage 50 Hz 3x	400 Volt
Total power required	44 kVA
Noise level	80 dB (A)
Machine's weight about	7500 kg

Overall dimensions machine:

Length	7500 mm
Width	4500 mm
Height	2628 mm

Various accessories:

Set of toolholders	SK 40 ca 150x
High pression colant device	40 bar
Coolant through spindle (cts)	
Tool setter Renishaw	
Lamp	
Rotating viewing window	
Switch cabinet Air conditioner	





























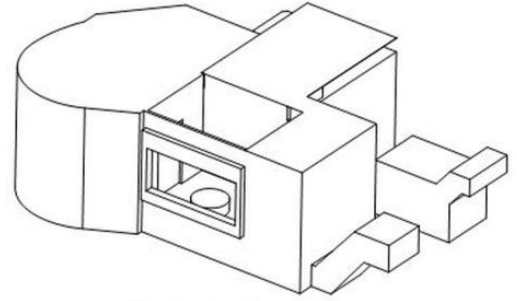
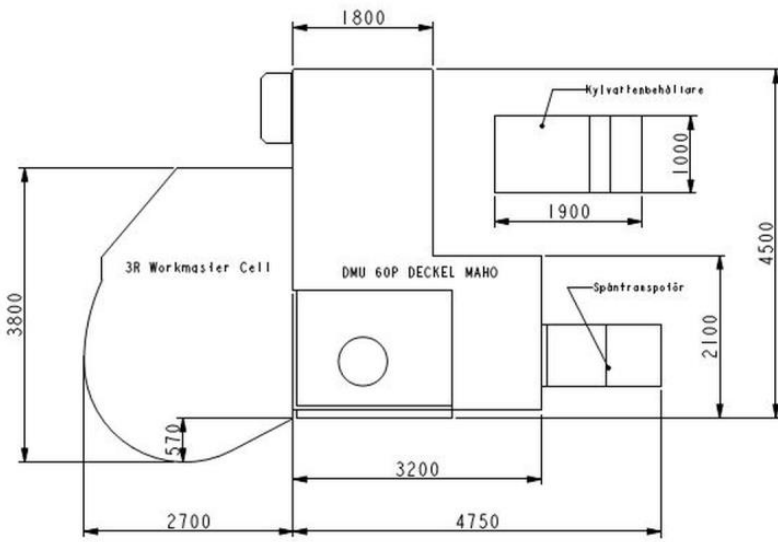
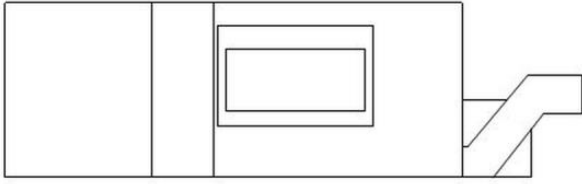

SCALE 2:125