



Inventory number: 23095

Milling machine gantry type  
FPT DINO  
HEIDENHAIN 530  
2002



### Technical data

Number of axis total	5
Travels:	
X axis	2800 mm
Y axis	800 mm
Z axis	1600 mm
Taper in spindle:	HSK 63
Spindle speeds:	
stepless	
from	0 rpm
up to	18000 rpm
Voltage 50 Hz 3x	380 Volt
Total installed power	68.7 kW
Overall dimensions about:	
Length	10500 mm
Width	3800 mm
Height	4600 mm
Various accessories:	
Chip conveyor	
Coolant system	
Handwheel electronic	
Switch cabinet Air conditioner	
Lamp	













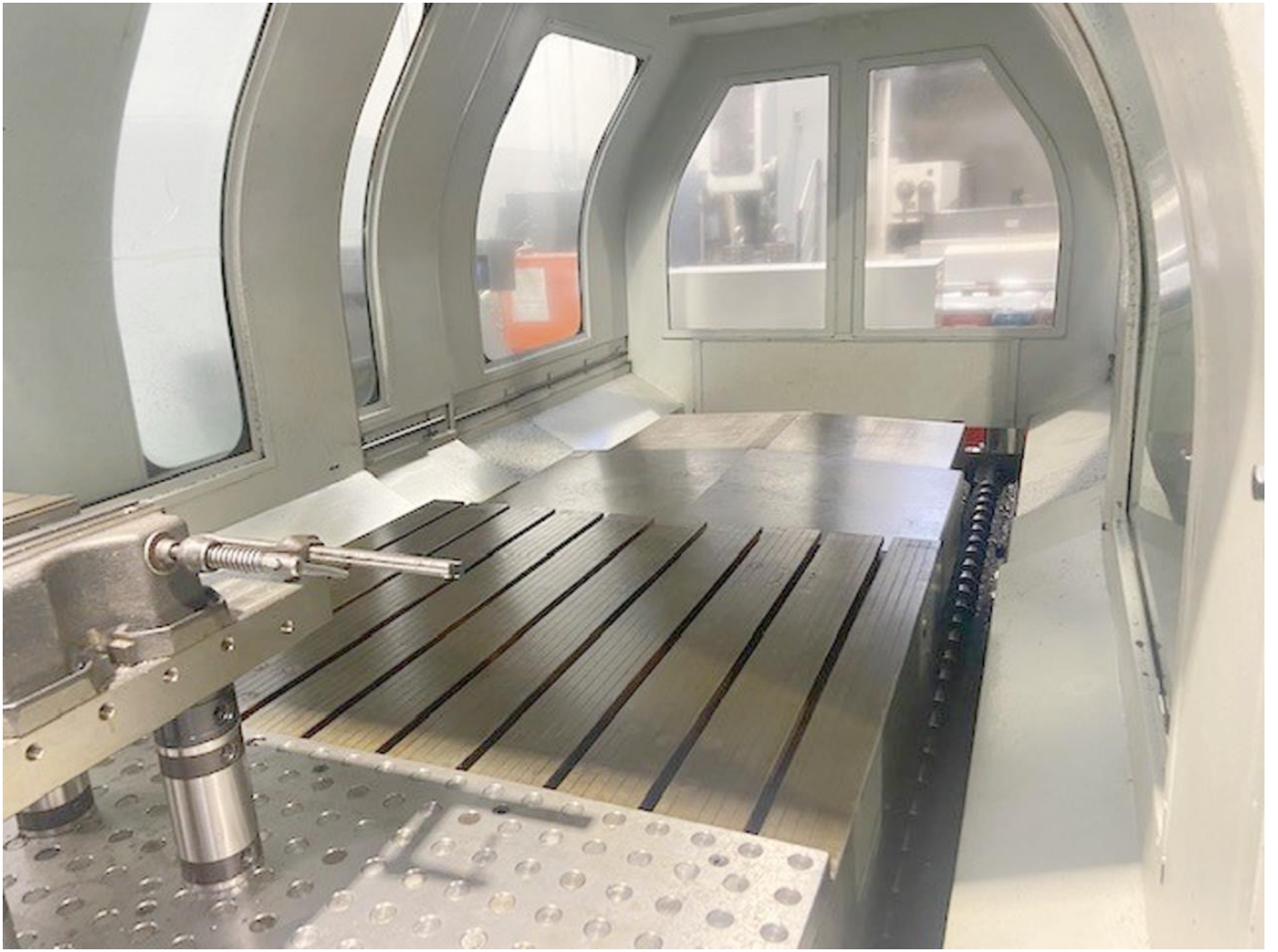











- il portale (4) sostiene nella parte superiore il carro (5) che nel suo movimento determina il "moto trasversale"
- il carro (5) sostiene la slitta (6) che nel suo movimento determina il "moto verticale"

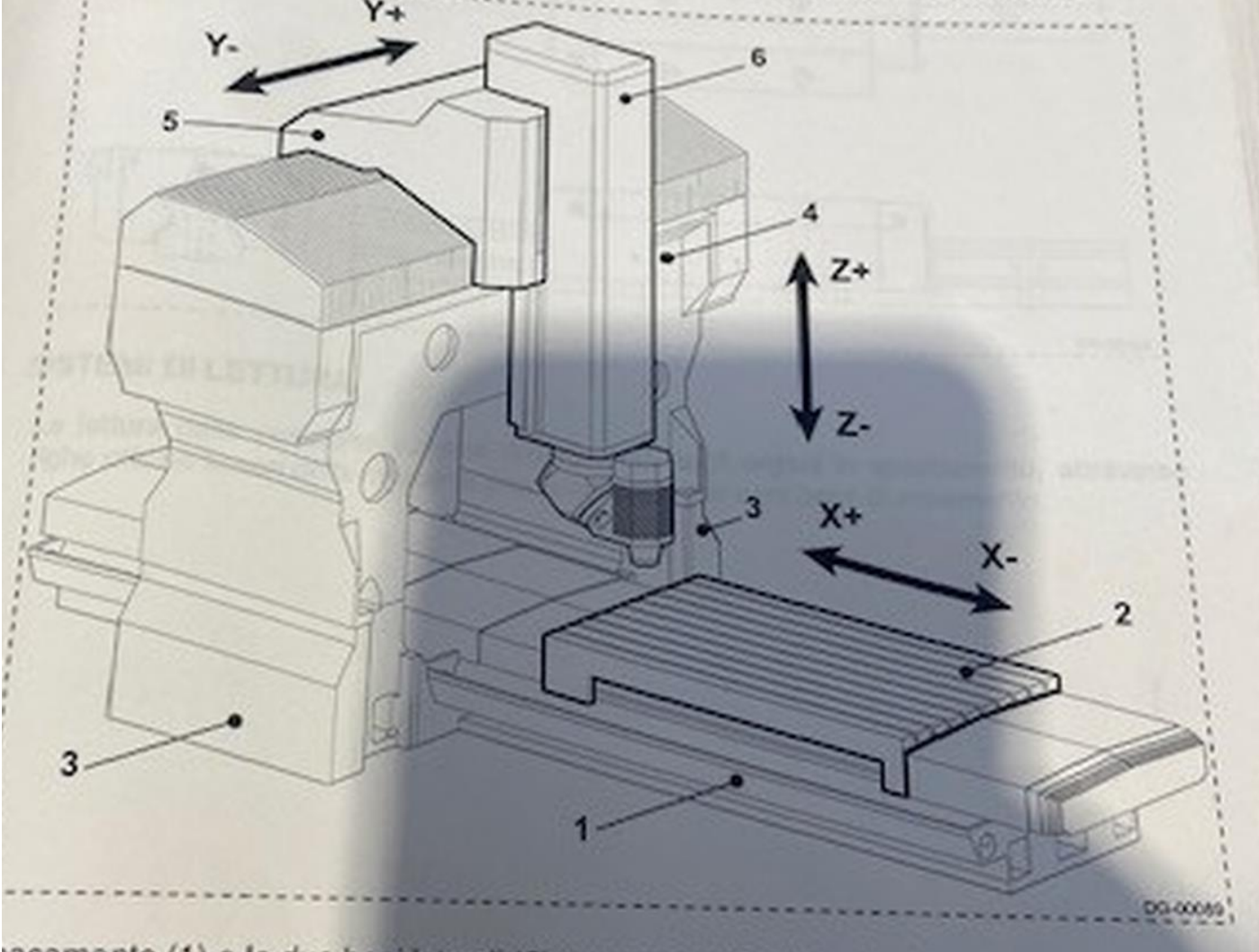

DG-00069