



Inventory number: 22769

CNC automatic lathe / CNC Swiss type
lathe

TORNOS DECO SIGMA 8

GE FANUC Series 32i-Model A

2006



Technical data

Number of axis total	5
Number of spindles	2
Max. turning diameter	10 mm
Max. drilling diameter	6 mm
Max. threading diameter	6 M (Metric)
Inner taper type	W15
Spindle speeds:	
stepless	
from	0 rpm
up to	15000 rpm
Spindle power	2.2 / 3.7 kW
Back spindle:	
speeds:	
from	0 rpm
up to	15000 rpm
Inner taper type	F13
Tool-holder:	
number of tools	17
Turning tools	7 pce
Drilling tools	4 pce
Counter-operation:	
Turning tools	2 pce
Drilling tools	4 pce
Rapid traverse X	20 m/min
Rapid traverse Y	40 m/min
Rapid traverse Z	20 m/min

Voltage	50 Hz 3x	400 Volt
Power of back spindle		2.2 / 3.7 kW
Air connect		6 bar
Total power required		8 kVA
Machine's weight about		1600 kg
Overall dimensions machine:		
Length		1670 mm
Width		870 mm
Height		1650 mm
Various accessories:		
C axis		
Bar feeder		
Manufacturer		LNS
Type		TRYTON 112
High pression colant device		
Fire extinguishing system		Kraft und Bauer
Status light		









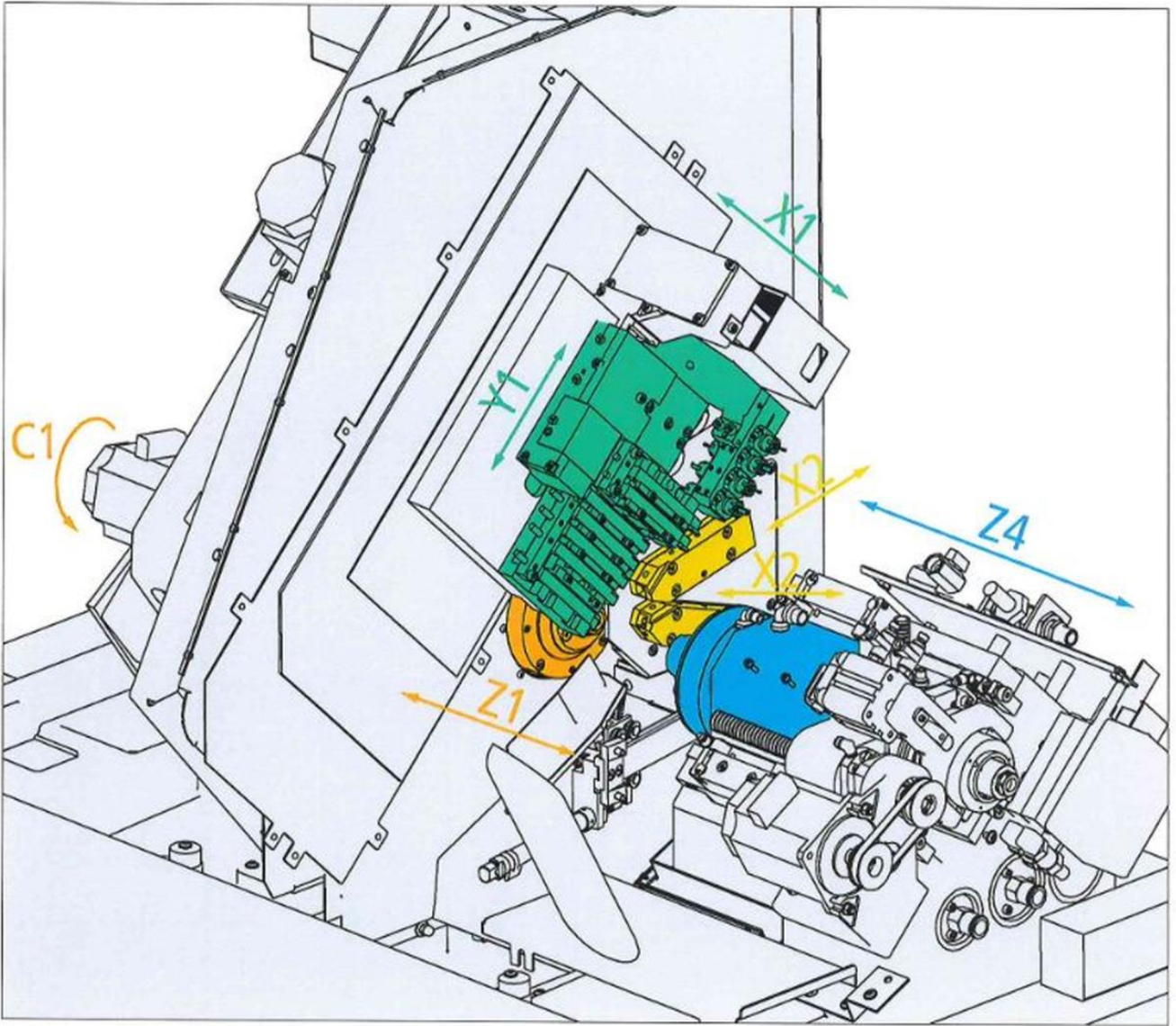

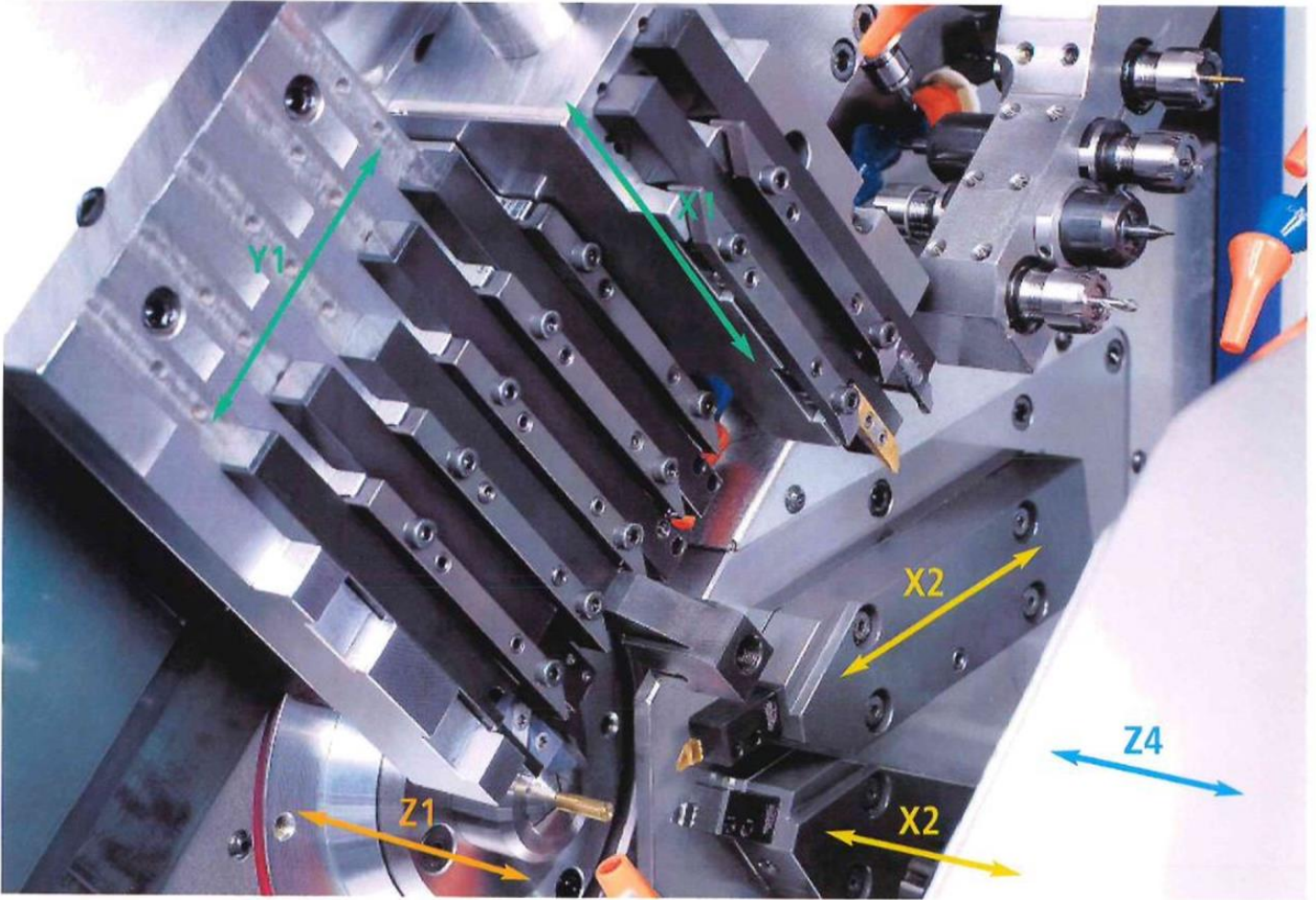



Acier inox
Ø 5 mm



Acier inox
Ø 7.6 mm



Acier inox
Ø 7 mm



Acier inox
Ø 5 mm



Acier inox
Ø 7 mm



Cube
Ø 1 mm



Titane
Ø 5 mm



Acier doux
Ø 5 mm



Leiton
Ø 6 mm



Acier doux
Ø 9 mm



Acier inox
Ø 5 mm



Acier inox
Ø 5 mm