



Inventory number: 22543

CNC double spindle lathe
MURATEC MT 100
MURATEC - FANUC CNC
2019



Technical data

Number of turning spindles	2
Number of revolvers	2
Swing diameter	190 mm
Spindle nose	JIS A2-5 mm
Max. bar diameter	51 mm
Turret slide: number	2
Number of positions turret 1	15
Number of positions turret 2	15
Driven tools turret	6000
Power of driven tools	2.2 kW
Upper turret head:	
X axis	150 mm
Y axis	+ / -30 mm
Z axis	620 mm
Lower turret head:	
X axis	150 mm
Y axis	+ / -30 mm
Z axis	620 mm
Main spindle:	
Spindle speeds:	
stepless	
from	0 rpm
up to	6000 rpm
Back spindle mobile:	
max. speed	6000 rpm
Back spindle stroke	680 mm

Rapid traverse X	24 m/min
Rapid traverse Z	40 m/min
Rapid traverse Y	12 m/min
Spindle motor	11 / 7.5 kW
Voltage 50 Hz 3x	400 Volt
Machine's weight about	8000 kg
Overall dimensions machine:	
Length	4120 mm
Width	2130 mm
Height	2815 mm
Various accessories:	
Set of collets	HAINBUCH SK52BZIG
Coolant system	
Oil mist extractor	FILTERMIST FX4002
Bar feeder	LNS
Type	ALPHA SL65 S
Handwheel electroinic	
C axis	
Chip conveyor	
Foot pedal	
Set of toolholders	
Measuring arm Renishaw	





































CAUTION

EXECUTE TOOLING CHANGE OF LIVE TOOL
AT TOOL INDEX POSITION.
WITH TWO PROVIDED WRENCHES.

UPPER OR RIGHT
TURRET

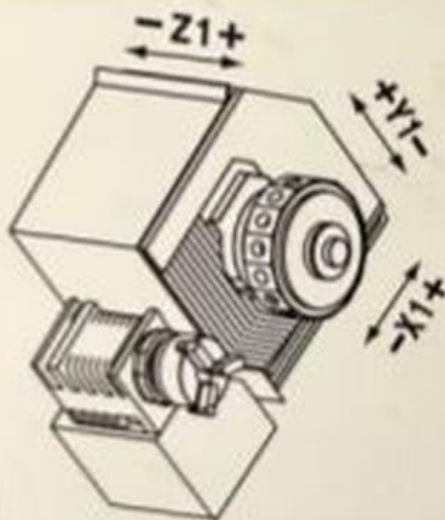
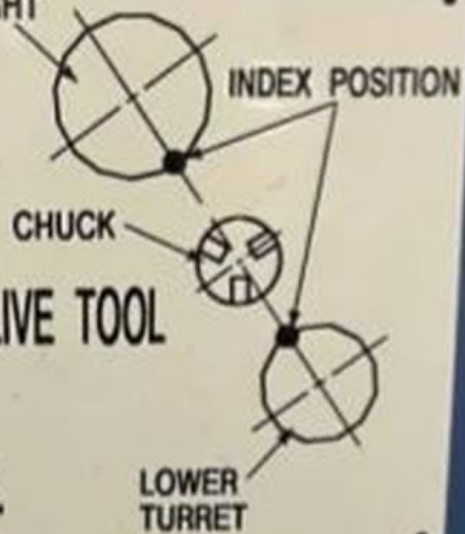

左軸
L-AXIS

MKZ-34776-69

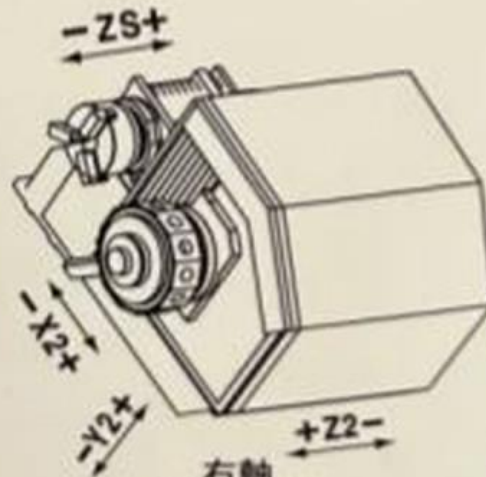

右軸
R-AXIS

MKZ-35032-68