



Inventarnummer: 23101

Horizontal Bearbeitungszenter
MAZAK HCN-6800
MAZATROL SMOOTH G
2016



Technische Daten

Anzahl Achsen total	4
Anzahl Tische	2
Längsweg (X-Achse)	1050 mm
Querweg (Y-Achse)	900 mm
Vertikalweg (Z-Achse)	980 mm
Werkstückgrösse max.:	
Höhe	1300 mm
Durchmesser	1050 mm
Max. Werkstückgewicht auf dem Tisch	1500 kg
Teilung des Tisches (B)	0.001 °
Palettenwechseleinrichtung:	
Anzahl	2
Länge	630 mm
Breite	630 mm
Werkzeugmagazin Anzahl Werkzeugplätze	120
Werkzeugdurchmesser max.	125 mm
Durchmesser bei freien Nebenplätzen	250 mm
Maximale Werkzeuglänge	630 mm
Werkzeuggewicht max.	30 kg
Werkzeugaufnahme: ISO	50
Abstand zwischen Spindelnase und Tisch	100 - 1000 mm
Spindeldrehzahl:	
Stufenlos	
von	0 U/min
bis	10000 U/min
Maximales Drehmoment	350 Nm

Eilgang	60 m/min
Anschluss 50 Hz 3x	400 Volt
Spindelleistung	30 / 37 kW
Maschinengewicht ca.	21500 kg
Abmessungen Maschine:	
Länge	6900 mm
Breite	4210 mm
Höhe	3400 mm
Diverses Zubehör:	
Hochdruck-Kühlmitteleinrichtung	50 bar
Werkzeugafter Renishaw	
Werkstücktaster Renishaw	
Späneförderer	
Elektronisches Handrad	
Beleuchtung	



















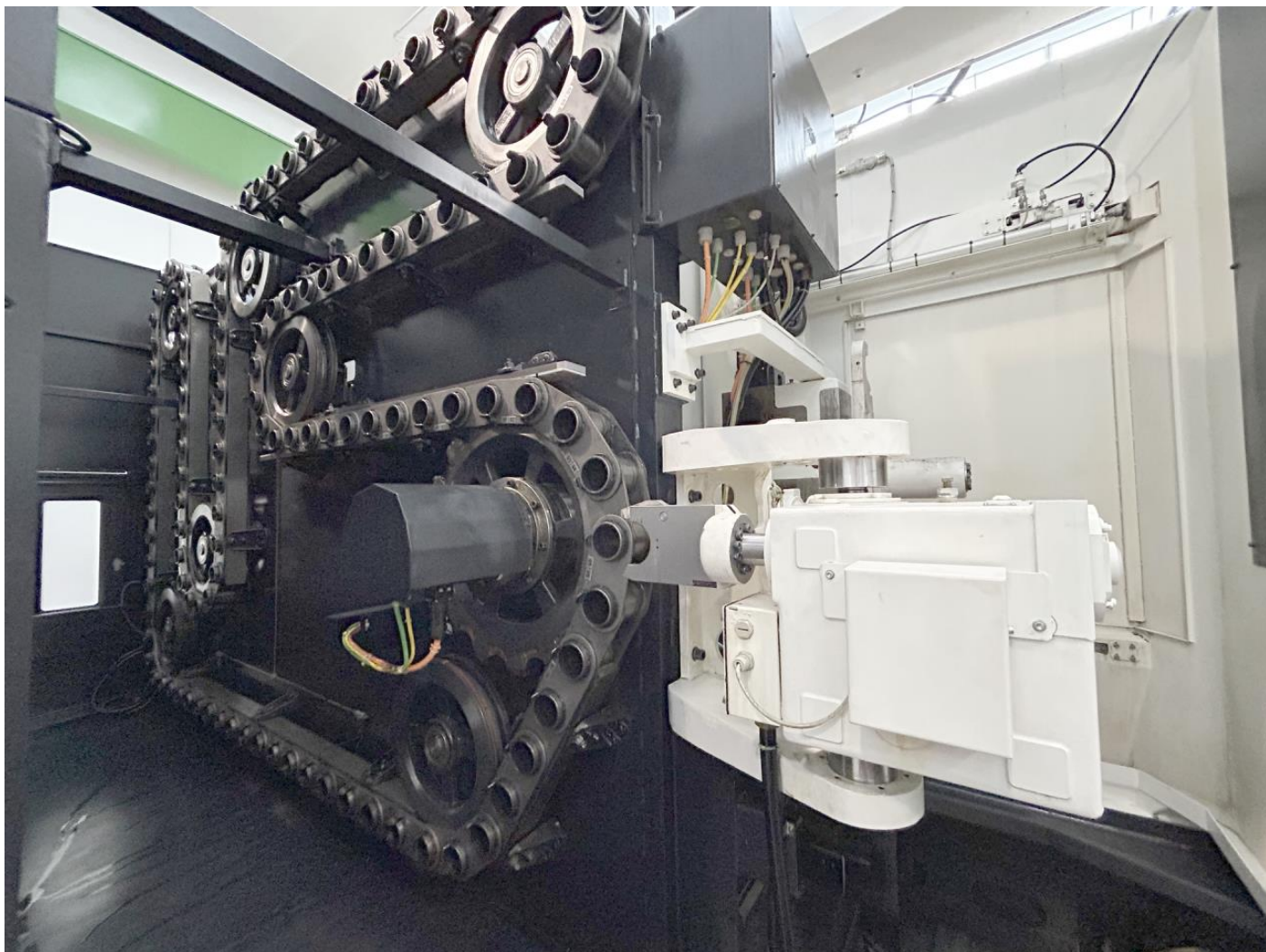













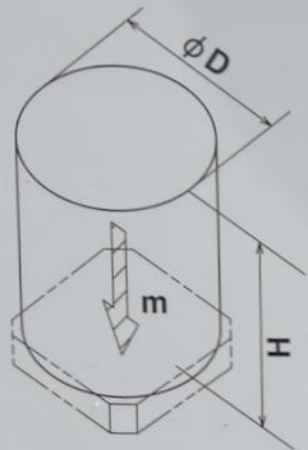

	$\phi D \leq \text{mm}$	$H \leq \text{mm}$	$m \leq \text{kg}$
<input type="checkbox"/> 630mm	1050	1300	1500
<input type="checkbox"/> 800mm	1050	1265	1300
630mm × 800mm	1050	1300	1440

02738100052

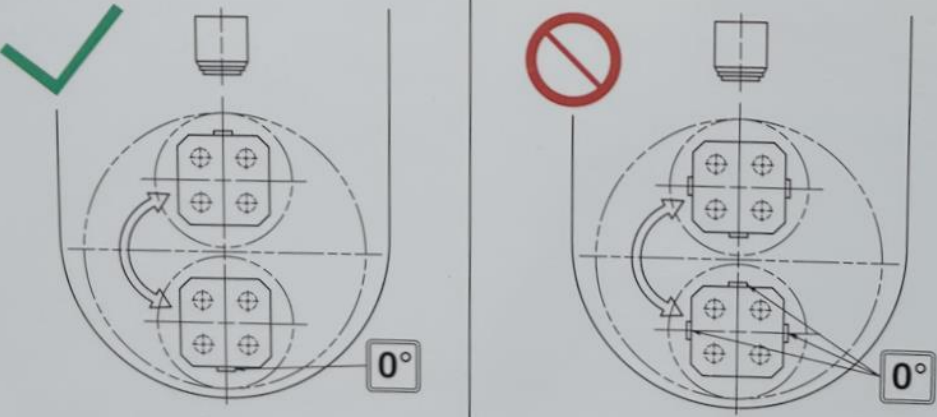

0F126200081