

**SAM 022524****TORNOS Art Micro 8**

<b>Gruppe</b>	CNC Langdrehautomat
<b>Hersteller</b>	TORNOS
<b>Art</b>	Micro 8
<b>Steuerung</b>	GE FANUC Series 32i-Model A
<b>Jahr</b>	2008



Anzahl Achsen total	7
Werkstücklänge max.	20 mm
Stangendurchmesser max.	10 mm
Spannzangenaufnahme Typ	W15
Spindeldrehzahlen:	
Stufenlos	
von	0 t/min
bis	12000 t/min
Gegenspindel:	
Drehzahlen:	
von	0 t/min
bis	12000 t/min
Spannzangenaufnahme Typ	F13
Eilgang X	20 m/min
Eilgang Y	40 m/min
Eilgang Z	20 m/min
Anschluss 50 Hz 3x	400 Volt
Spindelmotor	2.2 / 3.7 kW
Leistung der Gegenspindel	2.2 / 3.7 kW
Gesamtleistungsbedarf	8 kVA
Maschinengewicht ca.	1600 kg
Abmessungen Maschine:	
Länge	1670 mm
Breite	870 mm
Höhe	1650 mm

**Diverses Zubehör:**

C-Achse	
Lademagazin	
Fabrikat	LNS
Typ	TRYTEX 08
Baujahr	2009
Teileseparator	
Kühlmitteleinrichtung	
Kühlmittel-/ Nebelabsaugung	Donaldson
Zentriermikroskop	
Satz Spannzangen	
Schnittstelle RS 232	
Hochfrequenzspindel	2X
Zustandsleuchte	



[www.mullermachines.ch](http://www.mullermachines.ch)

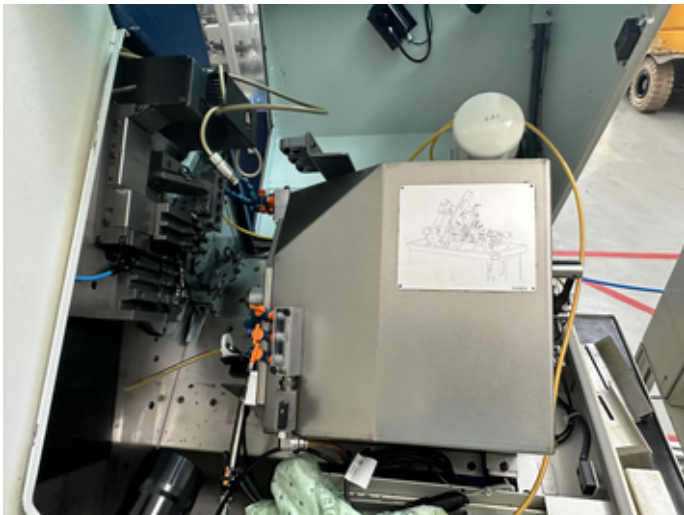
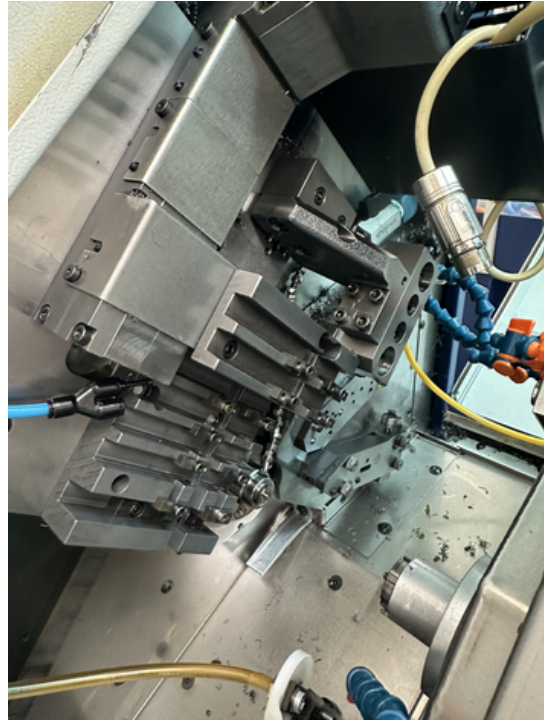

[www.mullermachines.ch](http://www.mullermachines.ch)

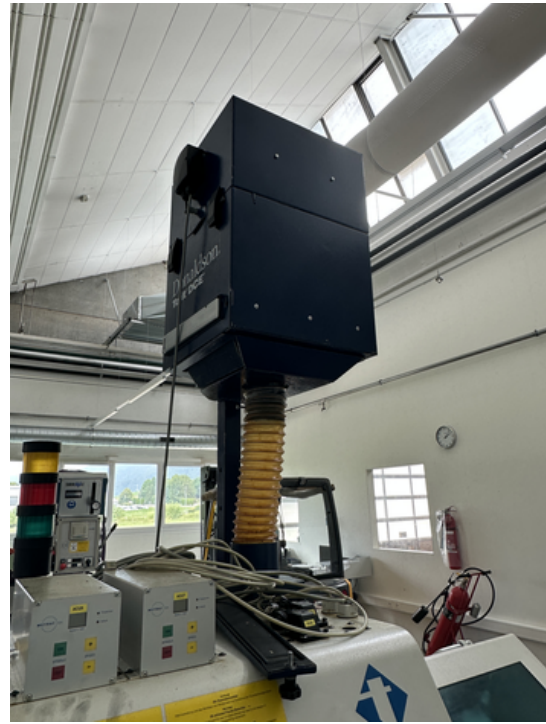

[www.mullermachines.ch](http://www.mullermachines.ch)

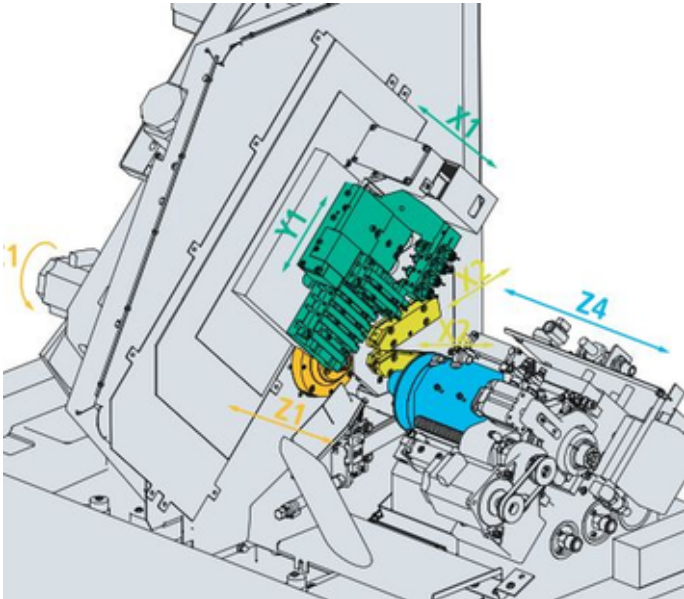

Automotive



Medical



Electronics



Watchmaking & Micromechanics

