

SAM 022307**HUAWIN Art PG250**

Gruppe	CNC Zahnradschleifmaschine
Hersteller	HUAWIN
Art	PG250
Steuerung	HUAWIN (FANUC / SIEMENS optional)
Youtube video	https://www.youtube.com/watch?v=OQLnVmHb1wc&t=6s



Schleifdurchmesser min.	20 mm
Schleifdurchmesser max.	250 mm
Min. Fusskreisdurchmesser	20
Min. Zähnezahl	1
Max. Zähnezahl	999
Max. Zahnteilung (Modul)	6
Min. Zahnteilung (Modul)	1
Verfahrwege:	
X-Achse	170 mm
Y-Achse	60 mm
Z-Achse	450 mm
C-Achse	360°
A-Achse	+/-45°
Drehzahl max.	10000 t/min
Schleifspindelmotor	17 kW
Gesamtleistungsbedarf	<20 kVA
Anschluss 50 Hz 3x	400 Volt
Maschinengewicht ca.	8000 kg
Abmessungen Maschine:	
Länge	2600 mm
Breite	2370 mm
Höhe	2155 mm

www.mullermachines.ch
Workpiece



- Precision profile using rotary dresser.
- Highly rigid box-type bed.
- Equipped with HMI for increasing operational efficiently.
- Linear motor X & Z-axis with zero backlash.
- DD motor of C-axis with zero backlash.

Specification

Workpiece	Spec	
	PG250	PG400
Min. Gear major diameter	Φ20 mm	Φ30 mm
Max. Gear outer diameter	Φ250 mm	Φ400 mm
Max.Module	6	10
Min.Module	0.5	
Number of teeth	1-999	
Stroke		
X-axis travel	170 mm	250 mm
Y-axis travel	60 mm	100 mm
Z-axis travel	450 mm	800 mm
C-axis	±360°	
A-axis	±45°	
C-axis(DD motor)	500 N.m	1300 N.m
Center distance	80/1000 mm	
Spindle power	17 kW	
Diameter of Spindle	170G	170G 220G
Outer diameter of grinding wheel	Φ50-Φ220	Φ50-Φ220 Φ210-Φ350
Max. speed of spindle	10000 rpm	10000rpm 4000rpm
Rotary dresser	Φ135 x 16W x R 0.3	
Air pressure source rated flow	30 L/min	
Air Pressure	0.5 Mpa	
Power capacity	< 20 KVA	
Machine dimension (L*W*H)	2600*2370*2155(mm)	
Machine weight	8000 kg	

Specification

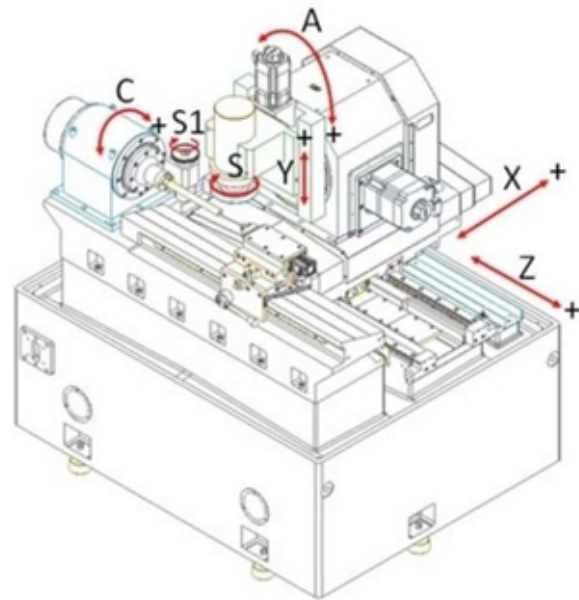
Workpiece	Spec	
	PG250	PG400
Min. Gear major diameter	Φ20 mm	Φ30 mm
Max. Gear outer diameter	Φ250 mm	Φ400 mm
Max.Module	6	10
Min.Module	0.5	
Number of teeth	1-999	
Stroke		
X-axis travel	170 mm	250 mm
Y-axis travel	60 mm	100 mm
Z-axis travel	450 mm	800 mm
C-axis	±360°	
A-axis	±45°	
C-axis(DD motor)	500 N.m	1300 N.m
Center distance	80/1000 mm	
Spindle power	17 kW	
Diameter of Spindle	170G	170G 220G
Outer diameter of grinding wheel	Φ50-Φ220	Φ50-Φ220 Φ210-Φ350
Max. speed of spindle	10000 rpm	10000rpm 4000rpm
Rotary dresser	Φ135 x 16W x R 0.3	
Air pressure source rated flow	30 L/min	
Air Pressure	0.5 Mpa	
Power capacity	< 20 KVA	
Machine dimension (L*W*H)	2600*2370*2155(mm)	
Machine weight	8000 kg	



www.mullermachines.ch

